

SELF-PRIMING JET PUMPS

JSPM



Range of performance

Flow rate: max 63 L/min (3.8m³/h)
Head: max 44m

Limits of use

Suction lift: max 7m
Liquid temperature: 40°C
Ambient temperature: 40°C

Uses and installations

The JSPM range is recommended for pumping clean water without abrasive particles and liquids that are chemically non aggressive for the materials used in the construction. Due to their reliability, simplicity of use and economy, they are suitable for domestic use, irrigation applications and specifically for the extraction of water from well points. The pump must be installed under a vented cover and protected against exposure to rain or water spray.

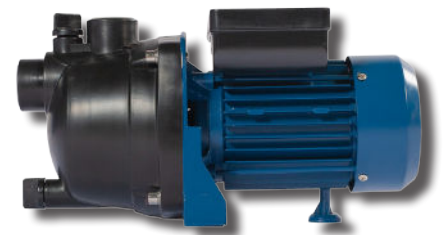

Construction Characteristics

Pump Body: Polypropylene
Impeller: Noryl
Motor Shaft: Stainless Steel 304
Mechanical Seal: Ceramic-graphite
Electric Motor: Single-phase 230V - 50Hz with capacitor and thermal overload protection.
Insulation: Class b
Protection: IP 44



Diagram

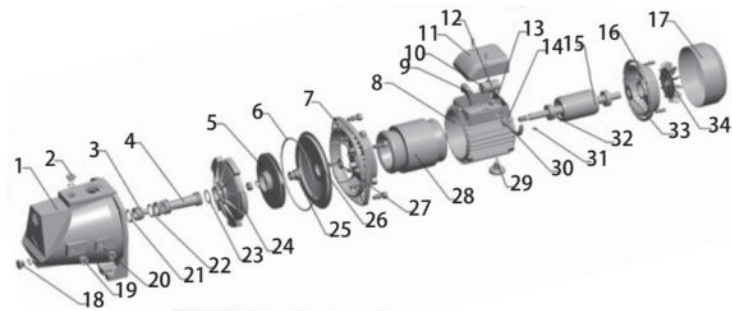

Diagram

No.	Description	No.	Description	No.	Description	No.	Description
1	Pump body	10	Capacitor	19	Air vent screw	28	Stator
2	Air vent screw	11	Capacitor cover	20	O-Ring	29	Foot
3	Nozzle	12	O-Ring	21	O-Ring	30	Cable
4	Venturi	13	Cable fixer	22	O-Ring	31	Key
5	Impeller	14	Cable protector	23	O-Ring	32	Bearing
6	O-Ring	15	Rotor	24	Guide vane	33	Wave Spring
7	Coupling	16	End Cover	25	Mechanical Seal	34	Fan
8	Motor bracket	17	Fan Cover	26	Pump cover		
9	Terminal board	18	Water vent screw	27	Water proof ring		

Hydraulic Performance Curve



Technical Data

NO	MODE	POWER		Q (m³/h)	0	0.6	1.2	1.8	2.4	3.0	3.6	3.8
	Single-phase	kW	HP	Q (l/min)	0	10	20	30	40	50	60	63
1	JSPM600	0.6	0.8	H (m)	36	30	25.34	20	9			
2	JSPM800	0.8	1.1		40	37.87	35.74	31.66	25	15		
3	JSPM1000	1	1.3		44	41.99	40	35	30	20	12.5	10

Dimension

No	Model	Freq.	Suct. Max	Size	Start-up Amps	Running Amps	Dimension	N/W
	Single-phase	Hz	m	inch	A	A	L x W x H mm	kg
1	JSPM600	50	7	1" x 1"	8.5	2.7	438x196x235	13
2	JSPM800	50	7	1" x 1"	13	4.2	438x196x235	13.5
3	JSPM1000	50	7	1" x 1"	16.5	5.3	438x196x235	14