

## Application

- It can be used to transfer clean water or other liquids similar to water in physical and chemical properties. It is suitable for industrial use and urban water supply, pressure boosting for high buildings and fire fighting, garden irrigation, long-distance water transfer, heating ventilation and air controlling, circulation and pressure boosting for cold and hot water, and supporting equipment etc.

## Pump

- Cast iron pump body and support under special anti-rust treatment
- AISI 304 shaft
- Max. liquid temperature: +60°C
- Max. suction: +8 m

## Motor

- C&U bearing
- Motor with copper winding
- Built-in thermal protector for single phase motor (≤1.5 kW)
- Insulation class: F
- Protection class: IPX4
- Max. ambient temperature: +40°C



## Identification Codes

**A C m 110 B 2**

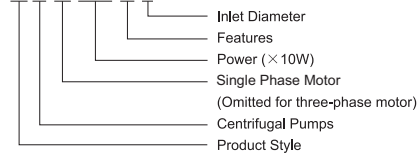

## Technical Data

MODEL		POWER		Q (m³/h)	0	6	9	12	15	18	21	24	30
Single Phase	Three Phase	kW	HP										
ACm60B2	AC60B2	0.6	0.8	H (m)	12.5	12	11.7	11	10.2	9.2	8	6.5	
ACm75B2	AC75B2	0.75	1		14	13.7	13.5	13	12.3	11.2	9.9	8.5	5.5
ACm110B2	AC110B2	1.1	1.5		19.5	19.2	19	18.5	17.7	16.5	15	13	8.5
ACm150B2	AC150B2	1.5	2		22	21.5	21	20.5	19.5	18.3	16.5	14.5	9.5

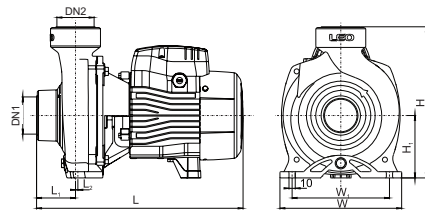

## Dimension

Model	DN1	DN2	L (mm)	W (mm)	H (mm)	L <sub>1</sub> (mm)	L <sub>2</sub> (mm)	W <sub>1</sub> (mm)	H <sub>1</sub> (mm)
ACm60B2	2"	2"	331	195	242	62.5	4	156	100
ACm75B2	2"	2"	331	195	242	62.5	4	156	100
ACm110B2	2"	2"	371	206	263	59	3.5	166	112
ACm150B2	2"	2"	371	206	263	59	3.5	166	112

## Hydraulic Performance Curve

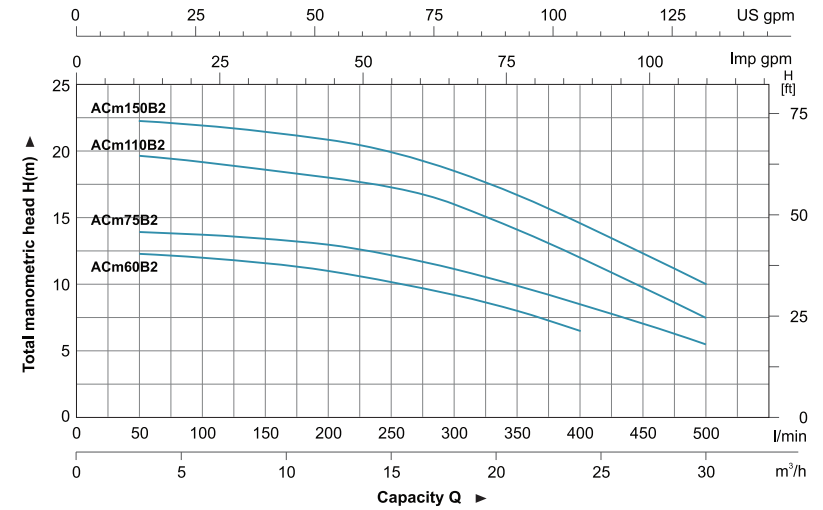

## Materials Table

No.	Part	Material
1	Pump body	HT200
2	Impeller	HPb59-1
3	Mechanical seal	Carbon/ceramic
4	Bracket cover	HT200
5	Oil seal	
6	Support	ZL102
7	Bearing	
8	Rotor	
9	Capacitor box	ABS
10	Stator	
11	Capacitor	
12	End plate	ZL102
13	Fan	PP
14	Fan cover	PP

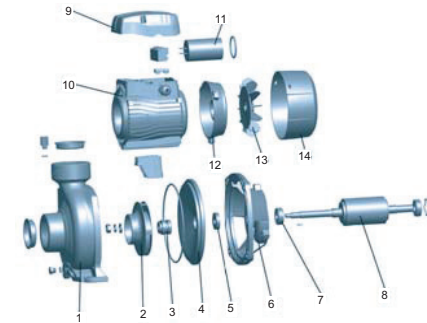

## Package Information

Model	GW (Kgs)	L (mm)	W (mm)	H (mm)	Quantity (PCS/20 TEU)
ACm60B2	14.4	375	214	265	1264
ACm75B2	15.2	375	214	265	1264
ACm110B2	19.9	415	225	280	1128
ACm150B2	20.7	415	225	280	1128