



Application

- Used In pressure sewage system
- Drainage of wastewater from individual residences, apartment buildings, recreational developments, models
- Transferring wastewater of commercial buildings, industrial plants, wastewater sampling, small hospitals
- Schools, federal, state and local parks, wastewater drainage
- To transfer various wastewater and sewage

Pump

- Semi-open vortex impeller & reliable grinding system
- Flexible installations with hoses, pipes or quick-coupling systems
- Float switch as standard accessory for single phase (≤1.1 kw)
- Cable Length: 10m
- Double-end mechanical seal
- Stainless steel welded shaft
- Liquid temperature: 0 - 40 °C
- Liquid PH value: 4 - 10
- Max. immersion depth: 10 m

Motor

- Frequency/Pole number: 50 Hz/2
- Insulation class: F
- Enclosures class: IP68
- Bearing: Ball type

Identification Codes

32 SW P m 3.6-17-1.1 L /QG

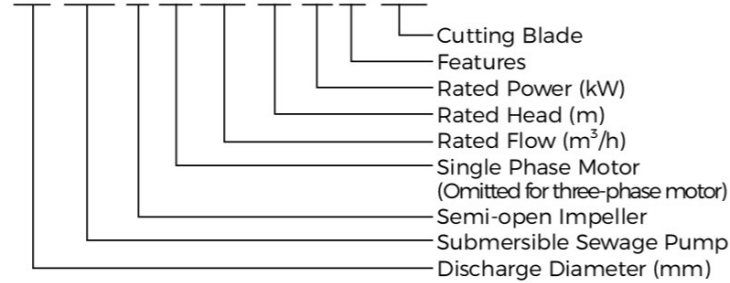

Technical Data

Model		Discharge	Power		Rated flow	Max. flow	Rated head	Max. head
Single Phase	Three Phase	mm (inch)	kW	HP	m³/h	m³/h	m	m
32SWPm3.6-17-1.1L/QG	32SWP3.6-17-1.1L/QG	32(1¼")	1.1	1.5	3.6	8	17	18
32SWPm3.6-23-1.5L/QG	32SWP3.6-23-1.5L/QG	32(1¼")	1.5	2	3.6	10	23	23.2
32SWPm3.6-30-2.2L/QG	32SWP3.6-30-2.2L/QG	32(1¼")	2.2	3	3.6	12	30	30.2

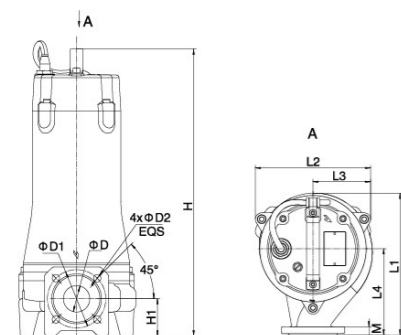

Dimension

Model	L1 (mm)	L2 (mm)	L3 (mm)	L4 (mm)	H (mm)		H1 (mm)	D (mm)	D1 (mm)	D2 (mm)	M (mm)
					1~	3~					
32SWP(m)3.6-17-1.1L/QG	230	191	96	140	473	473	73	32	90	14	16
32SWP(m)3.6-23-1.5L/QG					564	523					
32SWP(m)3.6-30-2.2L/QG					564	523					

Hydraulic Performance Curves

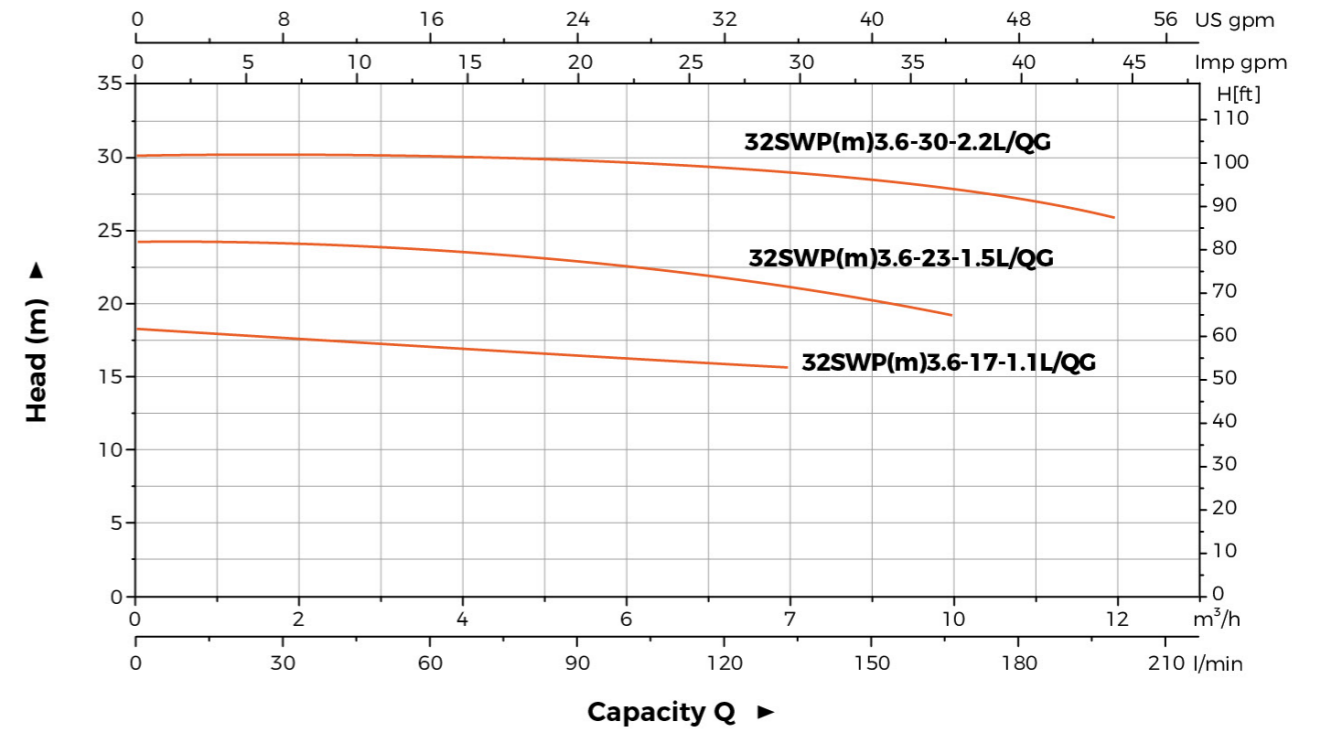

Material Table

No.	Part	Material
1	Handle	ZG45
2	Upper cover	HT200
3	Upper bearing seat	HT200
4	Motor body	HT200
5	Oil chamber	HT200
6	Pump cover	HT200
7	Pump body	HT200
8	Impeller	HT200
9	Cutting ring	108Cr17
10	Radial cutter	108Cr17
11	Oil seal	
12	Mechanical seal	Upper:SiC/Carbon Lower:SiC/SiC
13	Bearing	
14	Rotor	
15	Stator	

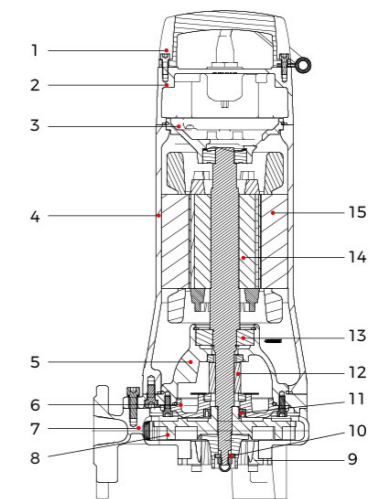

Package Information

Model	GW (kg)		L (mm)	W (mm)	H (mm)	Quantity (PCS/20'TEU)
	1~	3~				
32SWP(m)3.6-17-1.1L/QG	34	32.1	749	289	368	354
32SWP(m)3.6-23-1.5L/QG	41.5	38.4	924	284	363	294
32SWP(m)3.6-30-2.2L/QG	41.1	41.6	924	284	363	294