



Application

- Used In pressure sewage system
- Drainage of wastewater from individual residences, apartment buildings, recreational developments, models
- Transferring wastewater of commercial buildings, industrial plants, wastewater sampling, small hospitals
- Schools, federal, state and local parks, wastewater drainage
- To transfer various wastewater and sewage

Pump

- Semi-open vortex impeller & reliable grinding system
- Flexible installations with hoses, pipes or quick-coupling systems
- Cable Length: 10m
- Double-end mechanical seal
- Stainless steel welded shaft
- Liquid temperature: 0 - 40 °C
- Liquid PH value: 4 - 10
- Max. immersion depth: 10 m

Motor

- Frequency/Pole number: 50 Hz/2
- Insulation class: F
- Enclosures class: IP68
- Bearing: Ball type

Identification Codes

50 SW P 12 - 19 - 2.2 L /QG

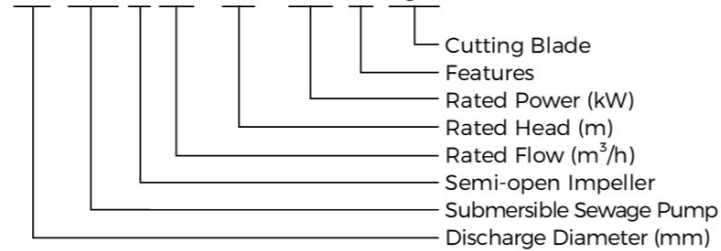

Technical Data

Model	Discharge	Power		Rated flow	Max. flow	Rated head	Max. head
	mm (inch)	kW	HP	m³/h	m³/h	m	m
50SWP10-10-1.1L/QG	50 (2")	1.1	1.5	10	20.5	10	17.5
50SWP12-15-1.5L/QG	50 (2")	1.5	2	12	21.5	15	19.5
50SWP12-19-2.2L/QG	50 (2")	2.2	3	12	24.5	19	23
50SWP12-22-3L/QG	50 (2")	3	4	12	26	22	25.5
50SWP12-30-4L/QG	50 (2")	4	5.5	12	26.5	30	33

Dimension

Model	L1 (mm)	L2 (mm)	L3 (mm)	L4 (mm)	H (mm)	H1 (mm)	D (mm)	D1 (mm)	D2 (mm)	M (mm)
50SWP10-10-1.1L/QG	245.5				472.5	73	40	100	14	16
50SWP12-15-1.5L/QG					523					
50SWP12-19-2.2L/QG	246	217	109	145	554	73	40	100	14	16
50SWP12-22-3L/QG										
50SWP12-30-4L/QG										

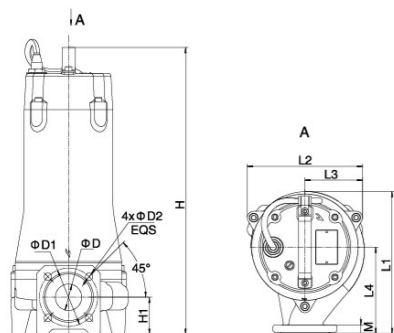

Hydraulic Performance Curves

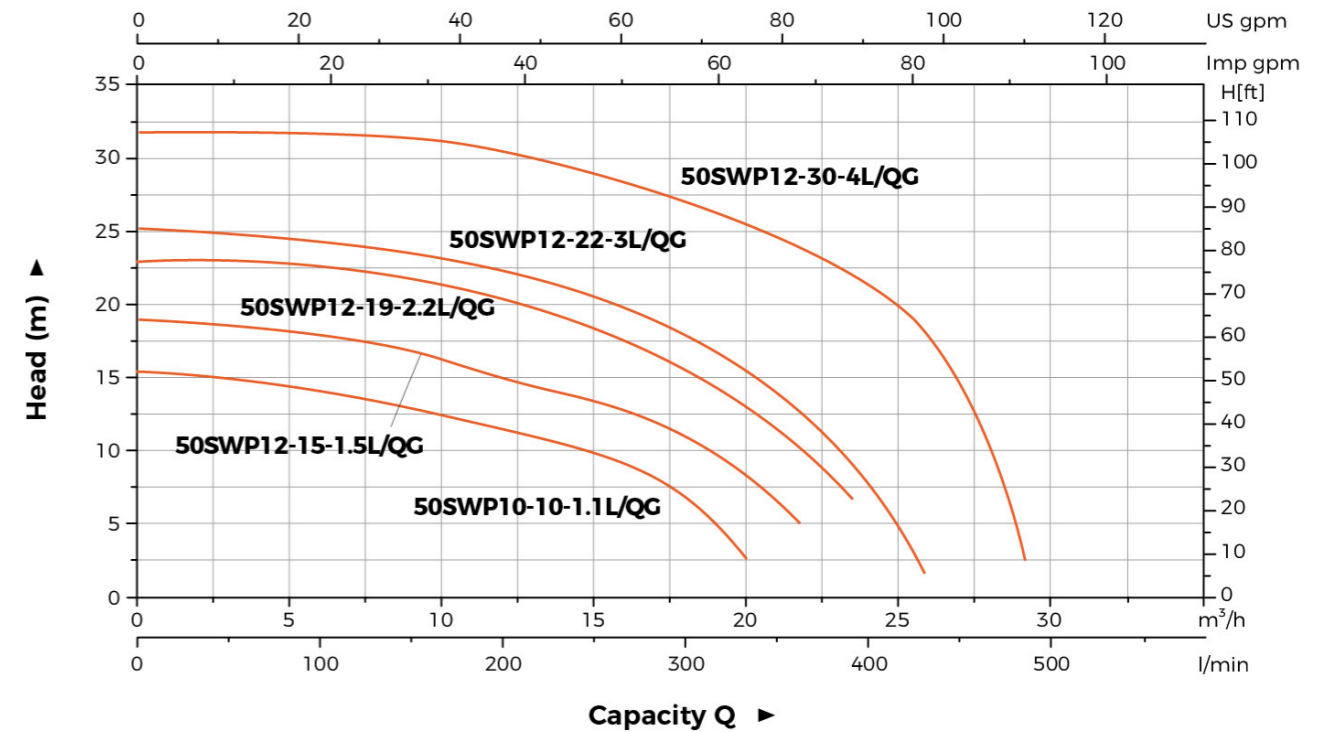

Material Table

No.	Part	Material
1	Handle	ZG45
2	Upper cover	HT200
3	Upper bearing seat	HT200
4	Motor body	HT200
5	Oil chamber	HT200
6	Pump cover	HT200
7	Pump body	HT200
8	Impeller	HT200
9	Cutting ring	108Cr17
10	Radial cutter	108Cr17
11	Oil seal	
12	Mechanical seal	Upper:Sic/Carbon Lower:Sic/Sic
13	Bearing	
14	Rotor	
15	Stator	

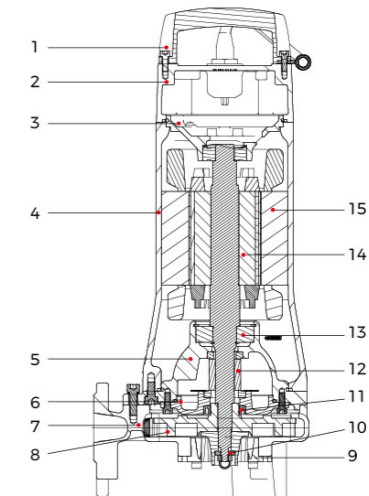

Package Information

Model	CW (kg)	L (mm)	W (mm)	H (mm)	Quantity (PCS/20'TEU)
50SWP10-10-1.1L/QG	39.7	749	289	368	354
50SWP12-15-1.5L/QG	46.8	924	284	363	294
50SWP12-19-2.2L/QG	45.2	924	284	363	294
50SWP12-22-3L/QG	51.5	874	284	363	316
50SWP12-30-4L/QG	53.9	874	284	363	316