

Hydraulic Performance Curves

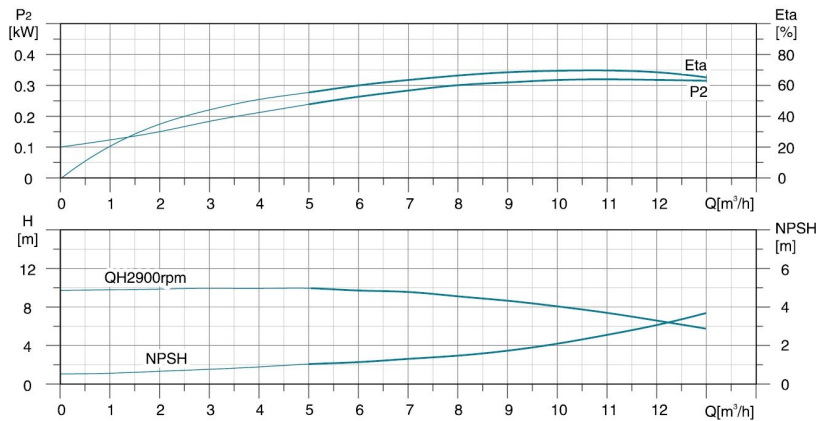

Dimension Drawing

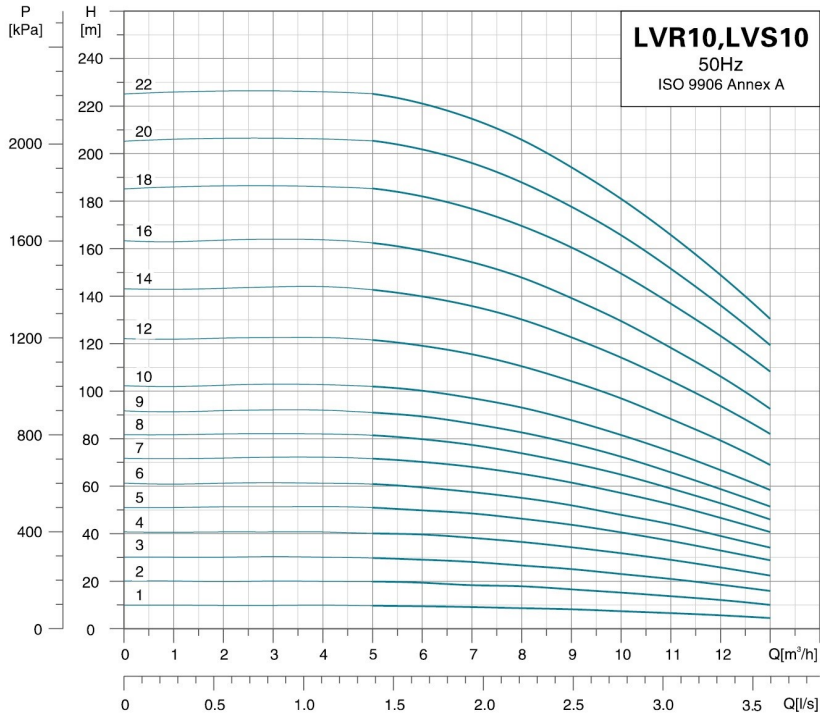
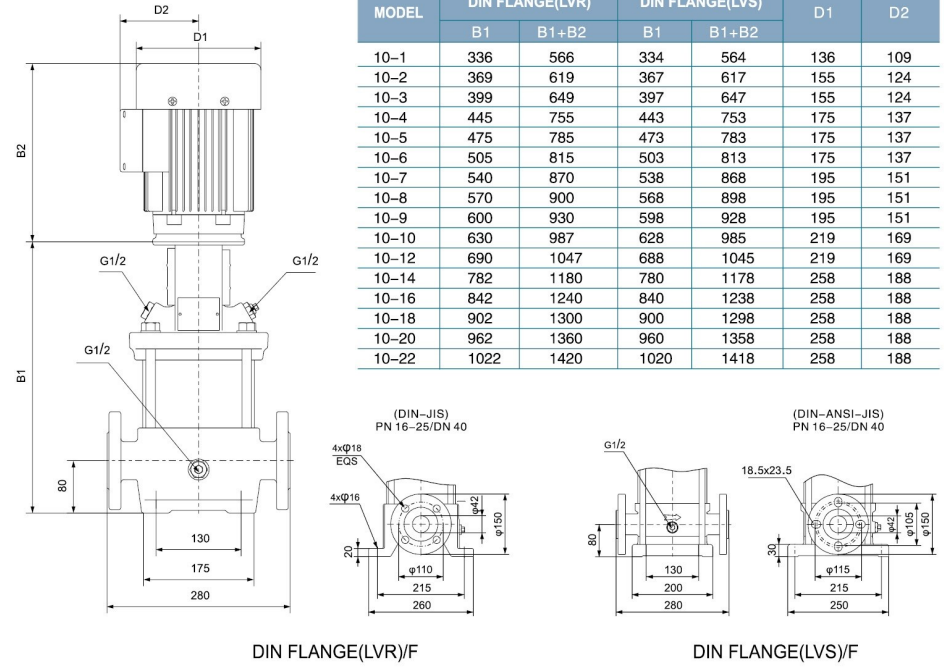

MODEL	DIN FLANGE(LVR)		DIN FLANGE(LVS)		D1	D2
	B1	B1+B2	B1	B1+B2		
10-1	336	566	334	564	136	109
10-2	369	619	367	617	155	124
10-3	399	649	397	647	155	124
10-4	445	755	443	753	175	137
10-5	475	785	473	783	175	137
10-6	505	815	503	813	175	137
10-7	540	870	538	868	195	151
10-8	570	900	568	898	195	151
10-9	600	930	598	928	195	151
10-10	630	987	628	985	219	169
10-12	690	1047	688	1045	219	169
10-14	782	1180	780	1178	258	188
10-16	842	1240	840	1238	258	188
10-18	902	1300	900	1298	258	188
10-20	962	1360	960	1358	258	188
10-22	1022	1420	1020	1418	258	188

MODEL	POWER[kW]	Q[m³/h]	2	4	6	8	10	12
10-1	0.37	H(m)	10	10	9	8	7.5	5
10-2	0.75		20	20	19	18	15	12
10-3	1.1		30	30	29	26	23	18
10-4	1.5		40	40	40	36	32	26
10-5	2.2		51	51	50	46	40	33
10-6	2.2		61	61	59	55	48	39
10-7	3.0		72	72	70	65	56	46
10-8	3.0		82	82	80	74	64	53
10-9	3.0		92	92	89	82	70	59
10-10	4.0		102	102	100	93	80	66
10-12	4.0		122	122	119	110	95	79
10-14	5.5		143	144	140	130	113	94
10-16	5.5	163	163	159	148	128	106	
10-18	7.5	185	186	182	169	147	123	
10-20	7.5	206	204	201	188	164	136	
10-22	7.5	226	226	221	206	178	147	