



Application

- Can be used to transfer clean water or other liquids similar to water in physical and chemical properties
- Suitable for lifting water from the well, sprinkling irrigation in garden, pressure boosting of running water, and supporting equipment etc.

Pump

- Cast iron pump body and support under special anti-rust treatment
- Stainless steel impeller
- AISI 304 shaft
- Max. liquid temperature: +60°C
- Max. suction: +9 m

Motor

- Low noise&Long life bearing
- Motor with copper winding
- Built-in thermal protector for single phase motor
- Insulation class: F
- Enclosures class: IPX4
- Max.ambient temperature: +50 °C

Identification Codes

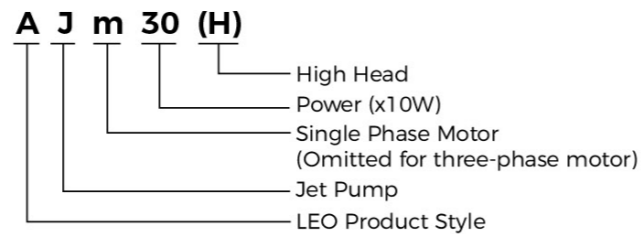

Optional plastic impeller
(only power less than 1kw)

Technical Data

Model	Power		Q(m³/h)	H (m)															
	kW	HP		0	0.3	0.6	0.9	1.2	1.5	1.8	2.1	2.4	2.8	3	3.3	3.6	3.9		
			Q(l/min)	0	5	10	15	20	25	30	35	40	47	50	55	60	65		
AJm30	0.3	0.4		33	30	26	22.5	20	18	16	14	-	-	-	-	-	-		
AJm45	0.45	0.6		38	36	32	28	25	22	20	18	-	-	-	-	-	-		
AJm60	0.6	0.8		44	41	37	33.5	31	28.5	26	24	22.5	21	-	-	-	-		
AJm75	0.75	1.0		40	38	36	34.5	33	31.5	30	29	28	27	26	25	24	23		
AJm75H	0.75	1.0		50	47	43	40	37	34.5	32	30	27.5	25	-	-	-	-		
AJm90	0.9	1.2		48	46	44	42.5	41	39.5	38	36	35	34	33	32	31	30		
AJm90H	0.9	1.2		60	57	53	49	46	43	40	37	35	33	-	-	-	-		

Dimension

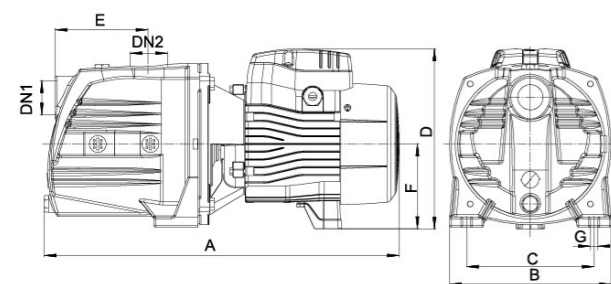

Model	DN1	DN2	A (mm)	B (mm)	C (mm)	D (mm)	E (mm)	F (mm)	G (mm)
AJm30	1"	1"	351	160	125	182	90	90	10
AJm45			351	160	125	182	90	90	10
AJm60			418	190	150	213	114	100	10
AJm75			418	190	150	213	114	100	10
AJm75H			418	190	150	213	114	100	10
AJm90			418	190	150	213	114	100	10
AJm90H			418	190	105	213	114	100	10

Hydraulic Performance Curves

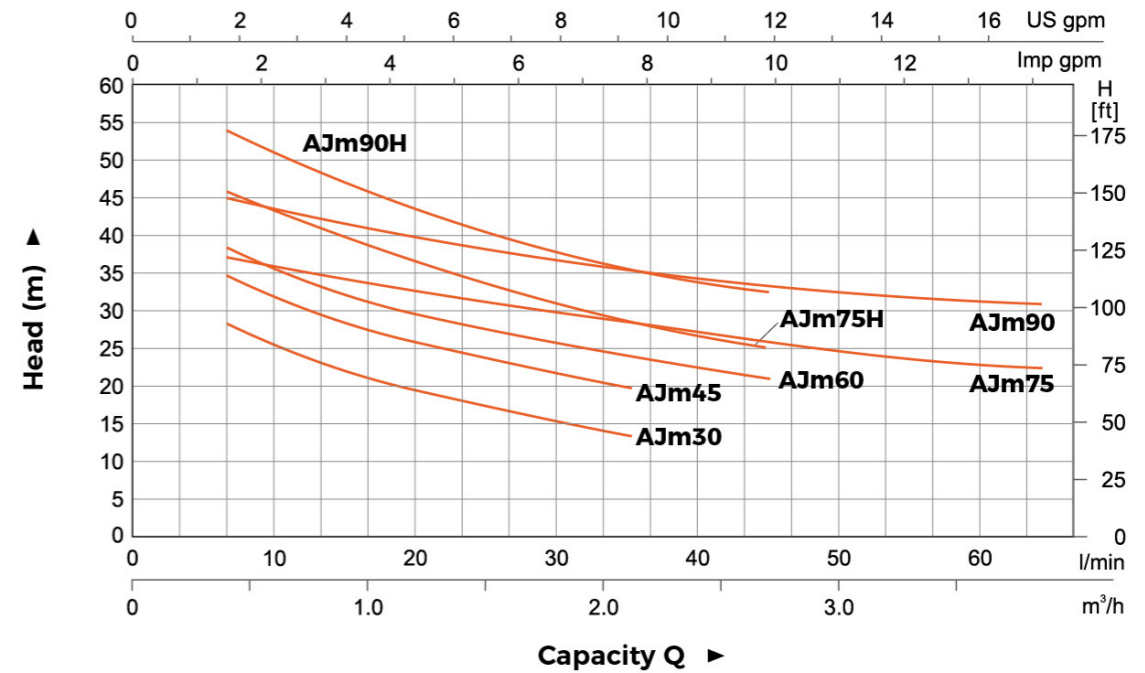

Material Table

No.	Part	Material	No.	Part	Material
1	Pump body	HT 200	13	Rear cover	ZL 102
2	Venturi tube	PPO	14	Capacitor	
3	Diffuser	PPO	15	Terminal box	PA6-GF25
4	Impeller	AISI 304	16	Terminal board	
5	Mechanical seal	Carbon/Ceramic	17	Stator	
6	O-ring	NBR			
7	Support cover	AISI 304			
8	Support	ZL 102			
9	Bearing				
10	Rotor				
11	Fan cover	PP			
12	Fan	PP			

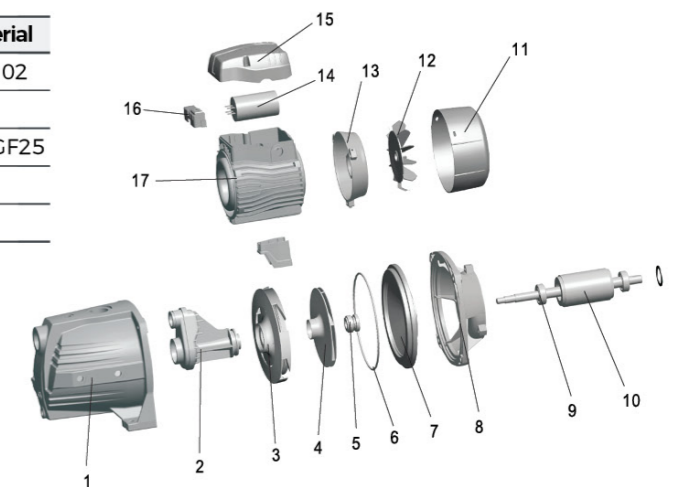

Package Information

Model	GW (Kgs)	L (mm)	W (mm)	H (mm)	Quantity (PCS/20'TEU)
AJm30	8.5	390	185	215	1740
AJm45	9.5	390	185	215	1740
AJm60	13.9	455	215	245	1170
AJm75	15	455	215	245	1170
AJm75H	15	455	215	245	1170
AJm90	16	455	215	245	1170
AJm90H	16	455	215	245	1170

